

Simply A Better Window & Door Header!

- 3-1/2" width for 2x4 construction.
- 5-1/2" width for 2x6 construction.
- Available in all depth sizes:
11-1/4", 9", 7-1/4", 5-1/2".
- Value engineered for commercial jobs.
Custom depths available (call for details).
- Full thermal break (foam core construction).
3-1/2" EH Lite2 = R8.4
5-1/2" EH Lite2 = R17.0
- Right size every time. Header is always straight, no cupping or twisting. Less call backs for drywall problems.
- Stock length is 14', custom lengths available.
- Precision End Trimmed (PET) available.

- Coated with LVL sealer.
- Bonded with exterior structural adhesive.
- One piece express installation.
No assembly needed.

3-1/2" Construction Description

- 1-1/2" LVL
- 1-1/2" Expanded Polystyrene (EPS)
- 7/16 OSB

5-1/2" Construction Description

- 1-1/2" LVL
- 3-1/2" Expanded Polystyrene (EPS)
- 7/16 OSB



5-1/2" pictured above.
LVL side should be installed facing out.

These tables must be used in conjunction with Freres code number PR-324 LVL.

Uniform Load (PLF) Allowable (1.5" Bearing Length Required at Each End)

SPAN	Header Depth			
	5-1/2"	7-1/4"	9"	11-1/4"
	LL L/360 TL L/240	LL L/360 TL L/240	LL L/360 TL L/240	LL L/360 TL L/240
3'	859	1121	1121	1120
3' 6"	736	961	960	959
4'	643	840	839	838
5'	468	671	671	670
6'	271	559	558	557

Uniform Load (PLF) Allowable (3" Bearing Length Required at Each End)

SPAN	Header Depth			
	5-1/2"	7-1/4"	9"	11-1/4"
	LL L/360 TL L/240	LL L/360 TL L/240	LL L/360 TL L/240	LL L/360 TL L/240
3'	859	1132	1445	1757
3' 6"	736	970	1238	1505
4'	643	848	1082	1317
5'	468	678	865	1052
6'	271	564	720	876
7'	170	390	617	750

ICC-ES Evaluation Reports

- ESR-1962 Foam
- PR-324 LVL

LVL manufactured by:



www.frereswood.com



DESIGN ASSUMPTIONS:

1. Span is inside edge to inside edge of supports and is valid for simple span headers only.
2. The allowable loads represent the capacity of the member in pounds per linear foot (plf) of length. The values in the tables are for uniform loads that are applied to the top of the LVL only.
3. Total Load is for normal (100% LDF) duration and is adjusted to account for the self-weight of the member.
4. Live Load (LL) deflection is limited to L/360. Total deflection is limited to L/240. Long term deflection (creep) has not been considered.
5. These tables assume full lateral support of the compression edge. Full support is considered to be a maximum unbraced length of 24".
6. These tables assume a plate (by others) on top of the header that is, at minimum, the width of the header in order to equally distribute loading between the outer lumber piles.
7. LVL lumber properties based on Freres LVL APA Product Report PR-L324 (Rev. 9.21.23).

NOTES:

1. The maximum Reactions are based on the compression strength perpendicular-to-grain, of the LVL. This is suitable for beams bearing on steel or the end-grain of studs.
2. Verify that the support for the beam is structurally adequate to carry the reaction. The compressive strength parallel-to-grain, of studs may require more studs than the bearing length above indicates.
3. For beams bearing on wood plates, the required bearing length will increase based on the bearing strength (compression perpendicular-to-grain) of the species and grade used for the plate material.
4. Verify local code requirements concerning minimum bearing.
5. No point loads.



EH LITE2
WINDOWS & DOORS

Nail (1) 10d nail into the top, middle and bottom of LVL.

Use 10d nails for lateral support 16" on center.

Nail (1) 10d nail into the trimmers on both sides.

LVL side should be installed facing out.

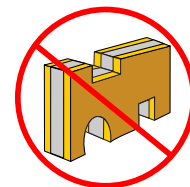

Never cut, drill, or notch the EH LITE2.

3-1/2" pictured above.
LVL side should be installed facing out.

Lateral support required along top edge.
Use 10d nails 16" on center maximum.

EH LITE2 needs to have 2-x nailed to top to control rotation.

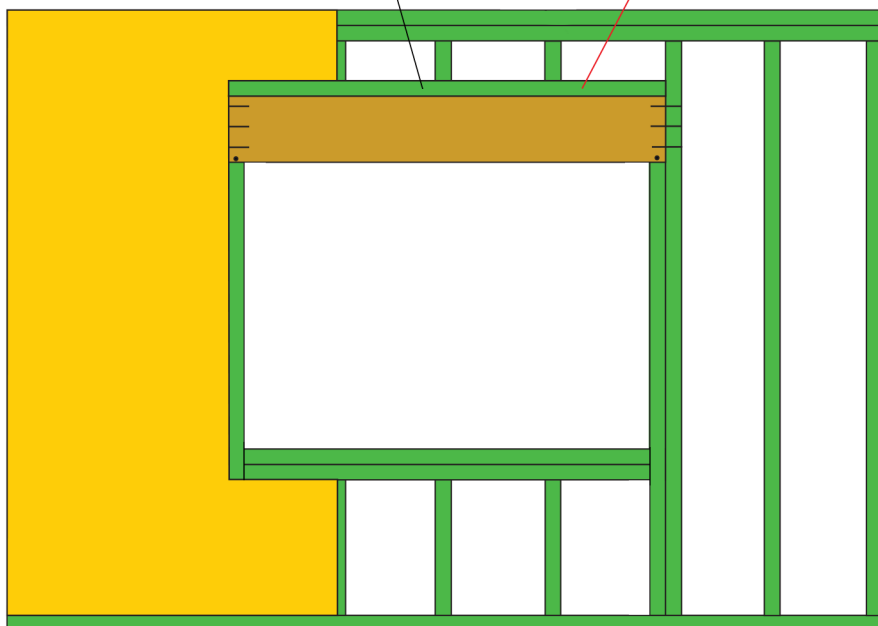

Nail for lateral support at bearing as indicated. Use 10d nails.

Toenailing Option

Toenail (3) 10d nails into LVL side of header.

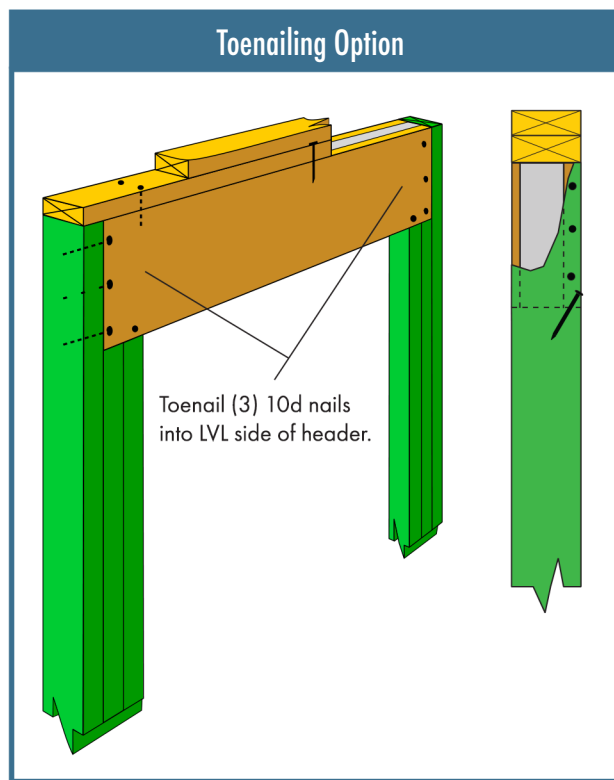

SJSComponents.com
ExpressHeader.com

Distributed by:
www.tsfp.com

